

# **MAC Viper XIP**

## **DMX Control Layout Guide**



**Martin**<sup>®</sup>

This guide covers firmware v.1.0.0

©2024 HARMAN PROFESSIONAL DENMARK ApS. All rights reserved. Features, specifications and appearance are subject to change without notice. HARMAN PROFESSIONAL DENMARK ApS and all affiliated companies disclaim liability for any injury, damage, direct or indirect loss, consequential or economic loss or any other loss occasioned by the use of, inability to use or reliance on the information contained in this document. Martin is a registered trademark of HARMAN PROFESSIONAL DENMARK ApS registered in the United States and/or other countries.

HARMAN PROFESSIONAL DENMARK ApS, Olof Palmes Allé 44, 8200 Aarhus N, Denmark  
HARMAN PROFESSIONAL, INC., 8500 Balboa Blvd., Northridge CA 91329, USA

**[www.martin.com](http://www.martin.com)**

MAC Viper XIP DMX Control Layout Guide, Revision B

**Table of contents**

- DMX protocols..... 4
  - Basic DMX Mode ..... 4
  - Extended DMX Mode ..... 10
  - Ludicrous DMX Mode..... 16
- Control/Settings DMX channel ..... 17
- Pan/tilt and zoom orientation guide..... 19

# DMX protocols

## Basic DMX Mode

### 54 DMX channels

Channel	DMX Value	Function	Fade type	Default value
<b>1</b>	0–19	<b>Strobe/shutter</b> Shutter closed	Snap	30
	20–49	Shutter open		
	50–200	Strobe slow → fast		
	201–210	Shutter open		
	211–255	Random strobe slow → fast		
<b>2</b>	0–65535	<b>Dimmer</b> Closed → Open	Fade	0
<b>3</b>				
<b>4</b>	0–65535	<b>Cyan</b> Intensity 0 → 100%	Fade	0
<b>5</b>				
<b>6</b>	0–65535	<b>Magenta</b> Intensity 0 → 100%	Fade	0
<b>7</b>				
<b>8</b>	0–65535	<b>Yellow</b> Intensity 0 → 100%	Fade	0
<b>9</b>				
<b>10</b>	0–65535	<b>CTO</b> Open (5800 K) → Warm (2850 K)	Fade	0
<b>11</b>				
<b>12</b>	0–37	<b>CTC (Color Temperature Control)</b> 2000 K 2000 K → 5750 K Open (5800 K) 5850 K → 12850 K	Fade	114
	38–113			
	114			
	115–255			
<b>13</b>	0–126	<b>Green/Magenta shift (tint)</b> Shift from Magenta / negative Duv to neutral No shift (native / on black body curve) Shift towards Green / positive Duv	Fade	128
	127–128			
	129–255			
<b>14</b>	0	<b>Color wheel</b> <b>Stepped selection</b> Open Slot 1 (Spectral Enhancement) Slot 2 (CTB) Slot 3 (Deep Orange) Slot 4 (Congo Blue) Slot 5 (Red) <i>No function</i> <b>Color wheel indexing</b> Open Open → Slot 1 Slot 1 Slot 1 → Slot 2 Slot 2 Slot 2 → Slot 3 Slot 3	Snap	0
	1			
	2			
	3			
	4			
	5			
	6–23			
	24			
	25–40			
	41			
	42–57			
	58			
	59–74			
75				

	76–91 92 93–108 109 110–125 126 127  128–137 138–147 148–157 158–167 168–177 178–187 188–191  192–214 215–216 217–239  240 241–255	Slot 3 → Slot 4 Slot 4 Slot 4 → Slot 5 Slot 5 Slot 5 → Open Open <i>No function</i> <b>Color wheel shake</b> Shake around Open 360° → 10° Shake around Slot 1 360° → 10° Shake around Slot 2 360° → 10° Shake around Slot 3 360° → 10° Shake around Slot 4 360° → 10° Shake around Slot 5 360° → 10° <i>No function</i> <b>Color wheel rotation</b> CW rotation fast → slow Stop (wheel stops at current position) CCW rotation slow → fast <b>Random color</b> Stop (wheel stops at currently selected color) Random color slow → fast		
15	0 1 2 3 4 5 6 7 8–127  128–136 137–145 146–154 155–163 164–172 173–181 182–190 191  192–215 216–239  240 241–255	<b>Gobo wheel 1 gobo selection</b> <b>Stepped selection</b> Open Slot 1 (Time Ripples) Slot 2 (Look Sharper) Slot 3 (Compass) Slot 4 (Deep Space) Slot 5 (Radar) Slot 6 (Short Cuts) Slot 7 (A Lot of Spots) <i>No function</i> <b>Gobo shake</b> (add indexing or rotation on next channel) Shake slot 1 360° → 10° Shake slot 2 360° → 10° Shake slot 3 360° → 10° Shake slot 4 360° → 10° Shake slot 5 360° → 10° Shake slot 6 360° → 10° Shake slot 7 360° → 10° <i>No function</i> <b>Gobo wheel rotation</b> CW rotation fast → slow CCW rotation slow → fast <b>Random gobo</b> Stop (wheel stops at currently selected gobo) Random gobo slow → fast	Snap	0
16	0–16383 16384 16385–32767	<b>Gobo wheel 1 gobo indexing/rotation</b> <b>Gobo indexing</b> Indexing -180° → 0° Indexed at 0° Indexing 0° → +180°	Fade	16384
17	32768–49150 49151–49152 49153–65535	<b>Gobo rotation</b> CW gobo rotation fast → slow Stop (gobo stops at current position) CCW gobo rotation slow → fast		

<b>18</b>	0 1 2 3 4 5 6 7 8–127	<b>Gobo wheel 2 gobo selection</b> <b>Stepped selection</b> Open Slot 1 (String Theory) Slot 2 (Hazy Waves) Slot 3 (Limbo) Slot 4 (Up Is Down) Slot 5 (Brush Up) Slot 6 (Sponge) Slot 7 (All Wrapped Up) <i>No function</i>	Snap	0
	128–136 137–145 146–154 155–163 164–172 173–181 182–190 191  192–215 216–239  240 241–255	<b>Gobo shake</b> (add indexing or rotation on next channel) Shake slot 1 360° → 10° Shake slot 2 360° → 10° Shake slot 3 360° → 10° Shake slot 4 360° → 10° Shake slot 5 360° → 10° Shake slot 6 360° → 10° Shake slot 7 360° → 10° <i>No function</i> <b>Gobo wheel rotation</b> CW rotation fast → slow CCW rotation slow → fast <b>Random gobo</b> Stop (wheel stops at currently selected gobo) Random gobo slow → fast		
<b>19</b>	0–16383 16384	<b>Gobo wheel 2 gobo indexing/rotation</b> <b>Gobo indexing</b> Indexing -180° → 0° Indexed at 0°	Snap	16384
<b>20</b>	16385–32767  32768–49150 49151–49152 49153–65535	Indexing 0° → +180° <b>Gobo rotation</b> CW rotation fast → slow Stop (gobo stops at current position) CCW rotation slow → fast		
<b>21</b>	0 1 2 3 4–23	<b>Animation wheel insertion</b> <b>Stepped insertion</b> Open Horizontal pattern Diagonal pattern Vertical pattern <i>No function</i>	Snap	0
	24 25–74 75 76–126 127  128–148 149–169 170–190 191  192 193–239	<b>Continuous insertion</b> Open Wheel insertion Horizontal pattern Diagonal patterns Vertical pattern <b>Wheel shake</b> Horizontal pattern shake slow → fast Diagonal pattern shake slow → fast Vertical pattern shake slow → fast <i>No function</i> <b>Bounce</b> Stop (wheel stops at current position) Bounce between horizontal and vertical slow → fast		

	240 241–255	<b>Random pattern</b> Stop (wheel stops at current pattern) Random patterns between horizontal and vertical slow → fast		
<b>22</b>	1–16383 16384 16385–32767	<b>Animation wheel indexing/rotation</b> <b>Animation wheel indexing</b> Indexing -180° → 0° Indexed at 0° Indexing 0° → +180°	Fade	16384
<b>23</b>	32768–49150 49151–49152 49153–65535	<b>Animation wheel rotation</b> CW rotation fast → slow Stop (wheel stops at current position) CCW rotation slow → fast		
<b>24</b>	0–255	<b>Frost 1</b> No frost → full frost	Fade	0
<b>25</b>	0–255	<b>Frost 2</b> No frost → full frost	Fade	0
<b>26</b>	0 1 2–127  128–191 192–255	<b>Prism selection</b> (select indexed angle and rotation on next channels) <b>Stepped selection</b> Open Prism 1 <i>No function</i> <b>Prism shake</b> Shake prism slow → fast <i>No function</i>	Snap	0
<b>27</b>	0–16383 16384 16385–32767	<b>Prism indexing/rotation</b> <b>Prism indexing</b> Indexing -180° → 0° Prism indexed at 0° Indexing 0° → +180°	Fade	16384
<b>28</b>	32768–49150 49151–49152 49153–65535	<b>Prism rotation</b> CW rotation fast → slow Stop (prism stops at current position) CCW rotation slow → fast		
<b>29</b>	0–191  192 193–223  224 225–255	<b>Iris</b> <b>Iris opening</b> Open → closed <b>Opening pulse</b> Stop (iris stops at current position) Opening pulse slow → fast <b>Closing pulse</b> Stop (iris stops at current position) Closing pulse slow → fast	Fade	0
<b>30</b>	0–65535	<b>Zoom</b> Wide → narrow	Fade	32768
<b>31</b>				
<b>32</b>	0–65535	<b>Focus</b> Infinity → near	Fade	32768
<b>33</b>				

<b>34</b>	0–255	<b>Framing blade 1 position</b> Out → in	Fade	0
<b>35</b>	0–126 127–128 129–255	<b>Framing blade 1 angle</b> Minimum Parallel Maximum	Fade	128
<b>36</b>	0–255	<b>Framing blade 2 position</b> Out → in	Fade	0
<b>37</b>	0–126 127–128 129–255	<b>Framing blade 2 angle</b> Minimum Parallel Maximum	Fade	128
<b>38</b>	0–255	<b>Framing blade 3 position</b> Out → in	Fade	0
<b>39</b>	0–126 127–128 129–255	<b>Framing blade 3 angle</b> Minimum Parallel Maximum	Fade	128
<b>40</b>	0–255	<b>Framing blade 4 position</b> Out → in	Fade	0
<b>41</b>	0–126 127–128 129–255	<b>Framing blade 4 angle</b> Minimum Parallel Maximum	Fade	128
<b>42</b>	0–126 127–128 129–255	<b>Framing rotation</b> Minimum Parallel Maximum	Fade	128
<b>43</b>	0–65535	<b>Pan</b> Left → right	Fade	32768
<b>44</b>				
<b>45</b>	0–65535	<b>Tilt</b> Forward → backward	Fade	32768
<b>46</b>				
<b>47</b>	<b>Fixture Control/Settings – see 'Control/Settings DMX channel' on page 17</b>			
<b>48</b>	0 1–127 128 129–254 255	<b>LED Frequency</b> Hybrid Variable -2% → 0% 2400 Hz Variable 0% → +2% <i>No function</i>	Snap	128



49	0–26	<b>P3 Mix</b> <b>DMX Mode</b> Intensity and colors fully controlled by DMX, P3 pixel data ignored	Snap	0
	27–228	<b>Mixed Mode</b> Crossfade from DMX control of intensity and colors to P3 control of intensity and colors: <ul style="list-style-type: none"> <li>• At 27, intensity and colors are still fully controlled by DMX.</li> <li>• Between 27 and 228, you mix/crossfade from DMX to P3 control.</li> <li>• At 228, the intensity of each of the 6 x <i>Animation</i> segments is controlled by 6 x separate P3 pixels and color is controlled by P3 Pixel 1 (the marked pixel on the P3 map).</li> </ul>		
	229–255	<b>Video Mode</b> Intensity of 6 x <i>Animation</i> segments controlled by 6 x P3 pixels, color controlled by DMX (DMX channels ‘color’ the P3 pixel data)		
50	0–255	<b>FX 1 (see table)</b> FX Selection 1 -255	Snap	0
51	0–126 127–128 129–255	<b>FX 1 Adjust</b> Backwards fast → slow Stop Forwards slow → fast	Fade	128
52	0–255	<b>FX 2 (see table)</b> FX Selection 1 -255	Snap	0
53	0–126 127–128 129–255	<b>FX 2 Adjust</b> Backwards fast → slow Stop Forwards slow → fast	Fade	128
54	0 1–35 36 37–100 101–120  121–140 141–255	<b>FX Synchronization</b> No sync Fixture offset (shift 10° → 350°) Synchronized <i>No function</i> Random start (FX1 adjust channel controls overall speed) Random duration <i>No function</i>	Snap	36

## Extended DMX Mode

### 64 DMX channels

Channel	DMX Value	Function	Fade type	Default value
<b>1</b>	0–19	<b>Strobe/shutter</b> Shutter closed Shutter open Strobe slow → fast Shutter open Random strobe slow → fast	Snap	30
	20–49			
	50–200			
	201–210			
	211–255			
<b>2</b>	0–65535	<b>Dimmer</b> Closed → Open	Fade	0
<b>3</b>				
<b>4</b>	0–65535	<b>Cyan</b> Intensity 0 → 100%	Fade	0
<b>5</b>				
<b>6</b>	0–65535	<b>Magenta</b> Intensity 0 → 100%	Fade	0
<b>7</b>				
<b>8</b>	0–65535	<b>Yellow</b> Intensity 0 → 100%	Fade	0
<b>9</b>				
<b>10</b>	0–65535	<b>CTO</b> Open (5800 K) → Warm (2850 K)	Fade	0
<b>11</b>				
<b>12</b>	0–37	<b>CTC (Color Temperature Control)</b> 2000 K 2000 K → 5750 K Open (5800 K) 5850 K → 12850 K	Fade	114
	38–113			
	114			
	115–255			
<b>13</b>	0–126	<b>Green/Magenta shift (tint)</b> Shift from Magenta / negative Duv to no shift No shift (native / on black body curve) Shift towards Green / positive Duv	Fade	128
	127–128			
	129–255			
<b>14</b>	0	<b>Color wheel</b> <b>Stepped selection</b> Open Slot 1 (Spectral Enhancement) Slot 2 (CTB) Slot 3 (Deep Orange) Slot 4 (Congo Blue) Slot 5 (Red) 6–23 <i>No function</i> <b>Color wheel indexing</b> Open Open → Slot 1 Slot 1 Slot 1 → Slot 2 Slot 2 Slot 2 → Slot 3 Slot 3 Slot 3 → Slot 4 Slot 4 Slot 4 → Slot 5 Slot 5	Snap	0
	1			
	2			
	3			
	4			
	5			
	6–23			
	24			
	25–40			
	41			
	42–57			
	58			
	59–74			
	75			
76–91				
92				
93–108				
109				

	110–125 126 127  128–137 138–147 148–157 158–167 168–177 178–187 188–191  192–214 215–216 217–239  240 241–255	Slot 5 → Open Open <i>No function</i> <b>Color wheel shake</b> Shake around Open 360° → 10° Shake around Slot 1 360° → 10° Shake around Slot 2 360° → 10° Shake around Slot 3 360° → 10° Shake around Slot 4 360° → 10° Shake around Slot 5 360° → 10° <i>No function</i> <b>Color wheel rotation</b> CW rotation fast → slow Stop (wheel stops at current position) CCW rotation slow → fast <b>Random color</b> Stop (wheel stops at currently selected color) Random color slow → fast		
<b>15</b>	0 1 2 3 4 5 6 7 8–127  128–136 137–145 146–154 155–163 164–172 173–181 182–190 191  192–215 216–239  240 241–255	<b>Gobo wheel 1 gobo selection</b> <b>Stepped selection</b> Open Gobo 1 (Time Ripples) Gobo 2 (Look Sharper) Gobo 3 (Compass) Gobo 4 (Deep Space) Gobo 5 (Radar) Gobo 6 (Short Cuts) Gobo 7 (A Lot of Spots) <i>No function</i> <b>Gobo shake</b> (add indexing or rotation on next channel) Shake Gobo 1, 360° → 10° Shake Gobo 2, 360° → 10° Shake Gobo 3, 360° → 10° Shake Gobo 4, 360° → 10° Shake Gobo 5, 360° → 10° Shake Gobo 6, 360° → 10° Shake Gobo 7, 360° → 10° <i>No function</i> <b>Gobo wheel rotation</b> CW rotation fast → slow CCW rotation slow → fast <b>Random gobo</b> Stop (wheel stops at currently selected gobo) Random gobo slow → fast	Snap	0
<b>16</b>	0–16383 16384 16385–32767	<b>Gobo wheel 1 gobo indexing/rotation</b> <b>Gobo indexing</b> Indexing -180° → 0° Indexed at 0° Indexing 0° → +180° <b>Gobo rotation</b> CW gobo rotation fast → slow Stop (gobo stops at current position) CCW gobo rotation slow → fast	Fade	16384
<b>17</b>	32768–49150 49151–49152 49153–65535	CW gobo rotation fast → slow Stop (gobo stops at current position) CCW gobo rotation slow → fast		

18	0	<b>Gobo wheel 2 gobo selection</b> <b>Stepped selection</b> Open Gobo 1 (String Theory) Gobo 2 (Hazy Waves) Gobo 3 (Limbo) Gobo 4 (Up Is Down) Gobo 5 (Brush Up) Gobo 6 (Sponge) Gobo 7 (All Wrapped Up) 8–127 <i>No function</i>	Snap	0
	128–136 137–145 146–154 155–163 164–172 173–181 182–190 191  192–215 216–239  240 241–255			
19	0–16383 16384	<b>Gobo wheel 2 gobo indexing/rotation</b> <b>Gobo indexing</b> Indexing -180° → 0° Indexed at 0° 16385–32767 Indexing 0° → +180° <b>Gobo rotation</b> CW rotation fast → slow Stop (gobo stops at current position) CCW rotation slow → fast	Snap	16384
20	32768–49150 49151–49152 49153–65535			
21	0	<b>Animation wheel insertion</b> <b>Stepped insertion</b> Open Horizontal pattern Diagonal pattern Vertical pattern 4–23 <i>No function</i> <b>Continuous insertion</b> Open Wheel insertion Horizontal pattern Diagonal patterns Vertical pattern <b>Wheel shake</b> Horizontal pattern shake slow → fast Diagonal pattern shake slow → fast Vertical pattern shake slow → fast 191 <i>No function</i> <b>Bounce</b> Stop (wheel stops at current position) Bounce between horizontal and vertical slow → fast	Snap	0
	24 25–74 75 76–126 127  128–148 149–169 170–190 191  192 193–239			

	240 241–255	<b>Random pattern</b> Stop (wheel stops at current pattern) Random patterns between horizontal and vertical slow → fast		
<b>22</b>	1–16383 16384 16385–32767	<b>Animation wheel indexing/rotation</b> <b>Animation wheel indexing</b> Indexing -180° → 0° Indexed at 0° Indexing 0° → +180°	Fade	16384
<b>23</b>	32768–49150 49151–49152 49153–65535	<b>Animation wheel rotation</b> CW rotation fast → slow Stop (wheel stops at current position) CCW rotation slow → fast		
<b>24</b>	0–255	<b>Frost 1</b> No frost → full frost	Fade	0
<b>25</b>	0–255	<b>Frost 2</b> No frost → full frost	Fade	0
<b>26</b>	0 1 2–127  128–191 192–255	<b>Prism selection</b> (select indexed angle and rotation on next channels) <b>Stepped selection</b> Open Prism 1 <i>No function</i> <b>Prism shake</b> Shake prism slow → fast <i>No function</i>	Snap	0
<b>27</b>	0–16383 16384 16385–32767	<b>Prism indexing/rotation</b> <b>Prism indexing</b> Indexing -180° → 0° Indexed at 0° Indexing 0° → +180°	Fade	16384
<b>28</b>	32768–49150 49151–49152 49153–65535	<b>Prism rotation</b> CW rotation fast → slow Stop (prism stops at current position) CCW rotation slow → fast		
<b>29</b>	0–49151	<b>Iris</b> <b>Iris opening</b> Open → closed	Fade	0
<b>30</b>	49152 49153–57343	<b>Opening pulse</b> Stop (iris stops at current position) Opening pulse slow → fast		
	57344 57345–65535	<b>Closing pulse</b> Stop (iris stops at current position) Closing pulse slow → fast		
<b>31</b>		<b>Zoom</b>	Fade	32768
<b>32</b>	0–65535	Wide → narrow		
<b>33</b>		<b>Focus</b>	Fade	32768
<b>34</b>	0–65535	Infinity → Near		

<b>35</b>	0-65535	<b>Framing blade 1 position</b> Out → in	Fade	0
<b>36</b>				
<b>37</b>	0-32766 32767-32768 32769-65535	<b>Framing blade 1 angle</b> Minimum Parallel Maximum	Fade	32768
<b>38</b>				
<b>39</b>				
<b>40</b>	0-65535	<b>Framing blade 2 position</b> Out → in	Fade	0
<b>41</b>				
<b>42</b>	0-32766 32767-32768 32769-65535	<b>Framing blade 2 angle</b> Minimum Parallel Maximum	Fade	32768
<b>43</b>				
<b>44</b>				
<b>45</b>	0-32766 32767-32768 32769-65535	<b>Framing blade 3 position</b> Out → in	Fade	0
<b>46</b>				
<b>47</b>				
<b>48</b>	0-65535	<b>Framing blade 3 angle</b> Minimum Parallel Maximum	Fade	32768
<b>49</b>				
<b>50</b>				
<b>51</b>	0-65535	<b>Framing blade 4 position</b> Out → in	Fade	0
<b>52</b>				
<b>53</b>				
<b>54</b>	0-32766 32767-32768 32769-65535	<b>Framing blade 4 angle</b> Minimum Parallel Maximum	Fade	32768
<b>55</b>				
<b>56</b>				
<b>57</b>	0-32766 32767-32768 32769-65535	<b>Framing rotation</b> Minimum Parallel Maximum	Fade	32768
<b>58</b>				
<b>59</b>				
<b>60</b>	0-65535	<b>Pan</b> Left → right	Fade	32768
<b>61</b>				
<b>62</b>	0-65535	<b>Tilt</b> Forward → backward	Fade	32768
<b>63</b>				
<b>64</b>	<b>Fixture Control/Settings – see 'Control/Settings DMX channel' on page 17</b>			
<b>65</b>	0 1-127 128 129-254 255	<b>LED Frequency</b> Hybrid Variable -2% → 0% 2400 Hz Variable 0% → +2% Reserved	Snap	128

59	0–26	<b>P3 Mix</b> <b>DMX Mode</b> Intensity and colors fully controlled by DMX, P3 pixel data ignored	Snap	0
	27–228	<b>Mixed Mode</b> Crossfade from DMX control of intensity and colors to P3 control of intensity and colors: <ul style="list-style-type: none"> <li>At 27, intensity and colors are still fully controlled by DMX.</li> <li>Between 27 and 228, you mix/crossfade from DMX to P3 control.</li> <li>At 228, the Intensity of each of the 6 x <i>Animotion</i> segments is controlled by 6 x separate P3 pixels and color is controlled by P3 Pixel 1 (the marked pixel on the P3 map).</li> </ul>		
	229–255	<b>Video Mode</b> Intensity of 6 x <i>Animotion</i> segments controlled by 6 x P3 pixels, color controlled by DMX (DMX channels ‘color’ the P3 pixel data)		
60	0–255	<b>FX 1 (see table)</b> FX Selection 1 -255	Snap	0
61	0–126 127–128 129–255	<b>FX 1 Adjust</b> Backwards fast → slow Stop Forwards slow → fast	Fade	128
62	0–255	<b>FX 2 (see table)</b> FX Selection 1 -255	Snap	0
63	0–126 127–128 129–255	<b>FX 2 Adjust</b> Backwards fast → slow Stop Forwards slow → fast	Fade	128
64	0	<b>FX Synchronization</b> No sync	Snap	36
	1–35	Fixture offset (shift 10° → 350°)		
	36	Synchronized		
	37–100	<i>No function</i>		
	101–120	Random start (FX1 adjust channel controls overall speed)		
	121–140	Random duration		
141–255	<i>No function</i>			

## Ludicrous DMX Mode

### 70 DMX channels

Channel	DMX Value	Function	Fade type	Default value
<b>Channels 1 – 64 as in Extended Mode</b>				
<b>65</b>	0–255	Intensity LED Segment 1 0 → 100%	Fade	255
<b>66</b>	0–255	Intensity LED Segment 2 0 → 100%	Fade	255
<b>67</b>	0–255	Intensity LED Segment 3 0 → 100%	Fade	255
<b>68</b>	0–255	Intensity LED Segment 4 0 → 100%	Fade	255
<b>69</b>	0–255	Intensity LED Segment 5 0 → 100%	Fade	255
<b>70</b>	0–255	Intensity LED Segment 6 0 → 100%	Fade	255

### Segment numbering

Ludicrous DMX mode gives individual control of the six LED segments that make up the light engine. The segments are numbered as shown below (fixture hanging downwards, display and connectors at back of fixture, pan at 50%, fixture tilted forward).

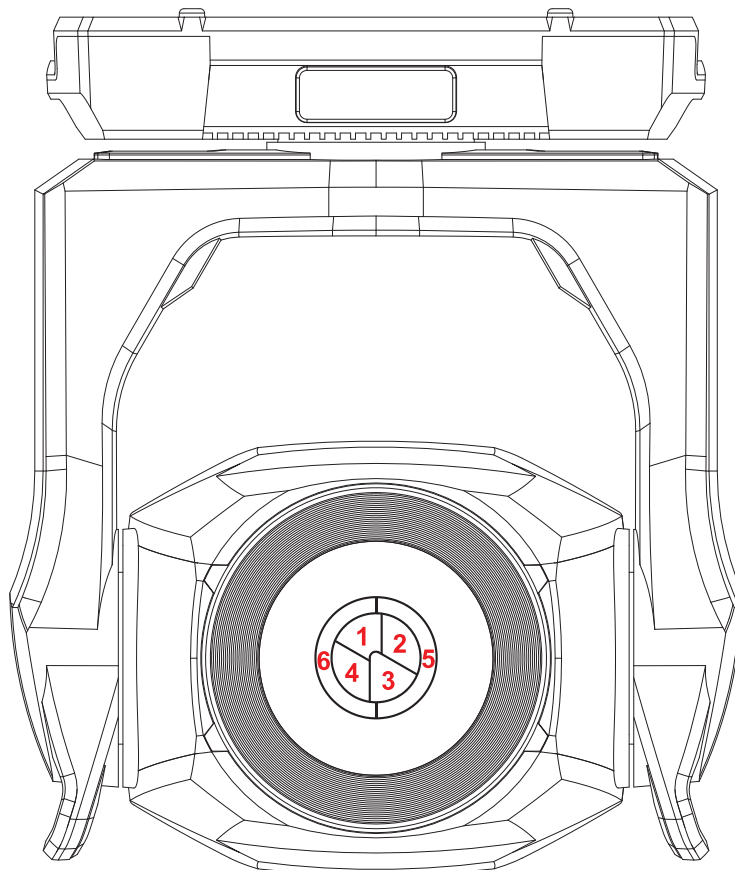



## Control/Settings DMX channel

The table below lists the control/settings functions available via DMX. They are implemented as follows:

- In Basic DMX Mode: on channel 47
- In Extended and Ludicrous DMX Modes: on channel 57

The commands on the Control/Settings channel must be held for a certain number of seconds in order to implement them. The required number of seconds is indicated after each command.

Channel	DMX value	Function	Fade type	Default value
Channel depends on DMX mode	0 - 9	<i>No function</i>	Snap	0
	10 - 14	Reset fixture		
	15	<i>No function</i>		
	16	Reset color		
	17	Reset beam		
	18	Reset pan and tilt		
	19–22	<i>No function</i>		
	23	Linear dimmer curve		
	24	Square law dimmer curve (default)		
	25	Inverse square law dimmer curve		
	26	S-Curve dimmer curve		
	27	Pan and tilt speed = standard (default)		
	28	Pan and tilt speed = fast		
	29	Pan and tilt speed = smooth		
	30	Parameter shortcuts = ON (default)		
	31	Parameter shortcuts = OFF		
	32	Disable focus tracking		
	33	Enable focus tracking at near distance		
	34	Enable focus tracking at medium distance (default)		
	35	Enable focus tracking at far distance		
	36	Enable video tracking		
	37	Disable video tracking (default)		
	38	Extended color mode		
	39	Calibrated color mode		
	40	Raw color mode (default)		
	41 - 51	<i>No function</i>		
	52	Control panel display = ON (default)		
	53	Control panel display = OFF		
	54	Regulated fan speed, fixed light output intensity (default)		
	55	Full fan speed, regulated light output intensity		
	56	Medium fan speed, regulated light output intensity		
	57	Low fan speed, regulated light output intensity		
	58	Ultra-low fan speed, regulated light output intensity		
59–60	<i>No function</i>			
61	Hibernation = ON			
62	Hibernation = OFF (default)			
63	Followspot = ON			
64	Followspot = OFF (default)			
65	Pan tilt limit = ON			
66	Pan tilt limit = OFF (default)			

67	Store lower pan limit		
68	Store upper pan limit		
69	Store lower tilt limit		
70	Store upper tilt limit		
71	Reset pan tilt limits		
72	Tungsten emulation = ON		
73	Tungsten emulation = OFF (default)		
74–78	<i>No function</i>		
79	Enable gobo CT correction (default)		
80	Disable gobo CT correction		
81–86	<i>No function</i>		
87	KeyLight calibration disabled		
88	KeyLight calibration manual		
89	KeyLight calibration automatic (default)		
90–99	<i>No function</i>		
100	Enable calibration		
101	Store pan and tilt calibration		
102	<i>No function</i>		
103	Store Cyan calibration		
104	Store Magenta calibration		
105	Store Yellow calibration		
106	Store CTC calibration		
107	Store all CMYC calibration		
108	Store Rotating Gobo 1 / Current slot index calibration		
109	Store Rotating Gobo 2 / Current slot index calibration		
110	<i>No function</i>		
111	Store beam effect/framing calibration		
112	Store iris calibration		
113	Store focus calibration		
114	Store zoom calibration		
115	Color wheel calibration		
116 - 193	<i>No function</i>		
194	Start CTO filter KeyLight calibration		
195	Start Spectral Enhancement filter KeyLight calibration		
196	Store CTO filter KeyLight calibration		
197	Store Spectral Enhancement filter KeyLight calibration		
198	Store all calibration values except KeyLight calibration		
199	Reset all calibration values to factory default (excluding KeyLight Calibration)		
200 – 255	<i>No function</i>		

# Pan/tilt and zoom orientation guide

Pan range = 540°

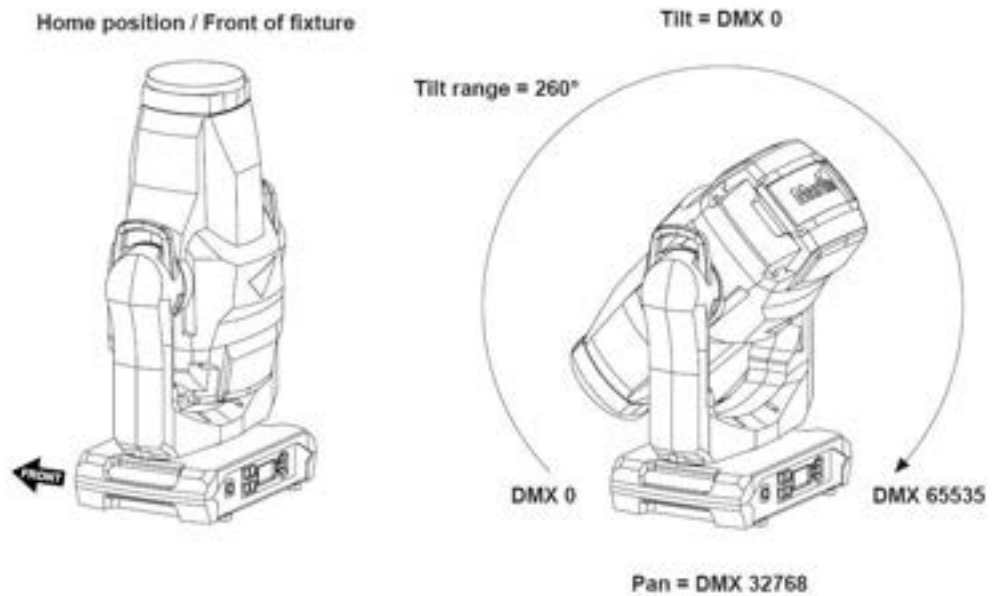
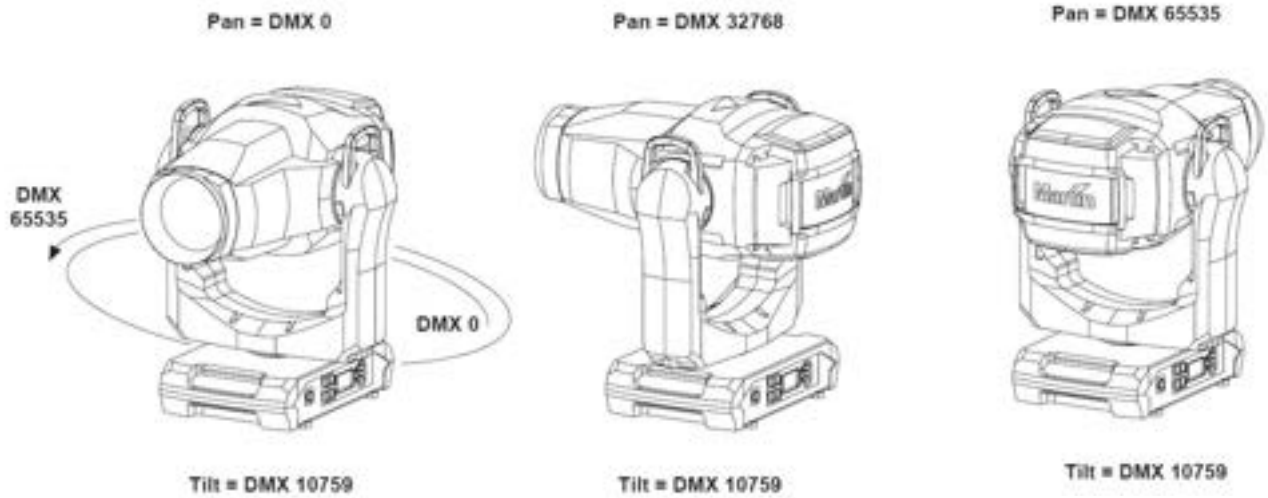

*Fixture shown in illustrations is for example purposes only*

Tilt = DMX 32768

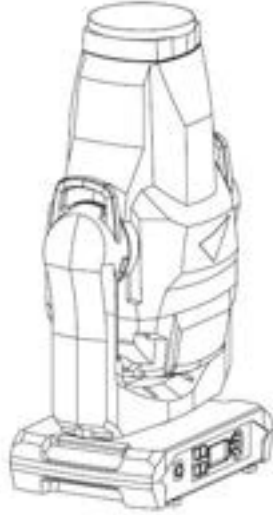

Pan = DMX 32768

Tilt = DMX 65535



Pan = DMX 32768

Zoom Wide = DMX 0

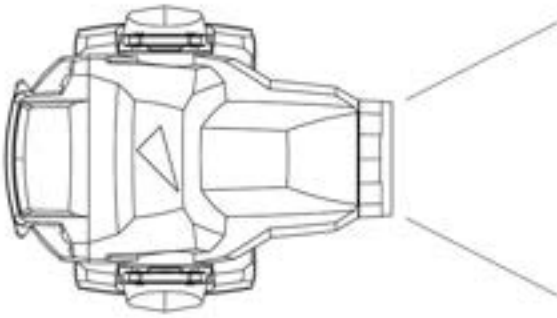

Zoom Narrow = DMX 65535

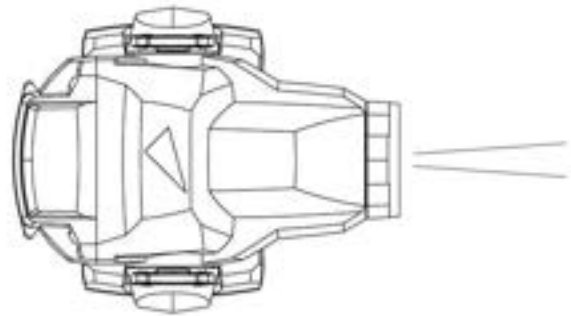

*Fixture shown in illustrations is for example purposes only*

**Martin**<sup>®</sup>

---

[www.martin.com](http://www.martin.com)